



**University of
Sunderland**

Elmarakbi, Ahmed, Ren, Qinglian, Trimble, Robert and Elkady, M (2013)
Performance Analysis of Hybrid and Full Electrical Vehicles Equipped with
Continuously Variable Transmissions. *Advances in Automobile Engineering*, 2
(1). pp. 1-8. ISSN 2167-7670

Downloaded from: <http://sure.sunderland.ac.uk/id/eprint/3593/>

Usage guidelines

Please refer to the usage guidelines at <http://sure.sunderland.ac.uk/policies.html> or alternatively contact sure@sunderland.ac.uk.

Integration of a Single Engine Model and a Boost System Model for Efficient Numerical Mapping of Engine Performance as it does at the cross-roads of Physics, Chemistry, Mechanics, Engineering Design and Materials Sciences, Automobile Technology is experiencing considerable growth as a result of recent technological advances. Automobile engineering has lot many opportunities in over the world. It is the study of engineering that deals with designing the vehicle, Manufacturing new products, new vehicle, Repairing, servicing vehicles.

AAE-open access gives barrier-free access to the literature for research. This is one of the fastest growing Engineering sector. AAE helps to introduce new motives and automotives to handle easy, simplified and stress free lifestyles of individuals in our daily.

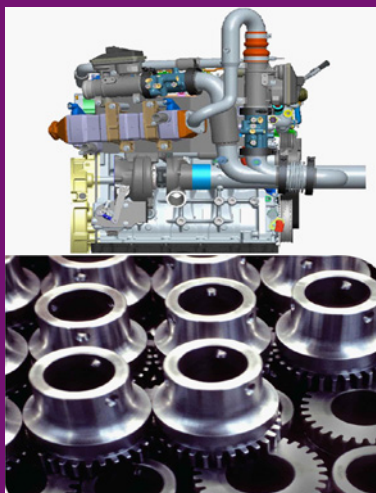

ISSN: 2167-7670

Advances in Automobile Engineering

Open Access

Editors & Editorial Board

<http://omicsgroup.org/journals/aaehome.php>



M El Sayed
Kettering University
USA



Craig J Hoff
Kettering University
USA



Mehdi Ahmadian
Virgina University
USA



Kalyan Annamalai
Texas A&M University
USA



Daniel M Chen
Central Michigan
University, USA



Nebojsa I Jaksic
Colorado State
University, USA



H Regenbrecht
Otago University
New Zealand



Jian Xie
IUPUIA Purdue
University, USA



Etim Ubong
Kettering University
USA



Shaopeng Cheng
Central Michigan
University, USA



Hongjoo Rhee
Mississippi State
University, USA



Gang Sheng
University of Alaska
USA



Petr Husek
Czech Technical
University, Prague



Tsung Chih Lin
Feng Chia University
Taiwan



Jie Zhang
University of Bristol
UK



Debjyoti Banerjee
Texas A&M University
USA



N Khosrow
Purdue University
USA



Yang Li
University of Sheffield
UK



Haofeng Chen
University of
Strathclyde, UK



E Desapriya
University of British
Columbia, Canada



Hossein Parsaei
University of
Waterloo, Canada



Ma Ji Luo
Wuhan University of
Technology, China



M Maragoudakis
University of the
Aegean, Greece



M A Khanesar
K. N. Toosi University
of Tech, Iran



K Jaojaruek
Kasetsart University
Thailand



Owen Falzon
University of Malta
Malta



Margaret Stack
University of Strathclyde
Engineering, USA



Andrew Nee Yeh C
National University of
Singapore, Singapore



Mamidala Ramulu
University of
Washington, USA



Anwar Soheli
IUPUIA Purdue
University, USA



Hong Tong Low
National University of
Singapore, Singapore



Zhang Yunfeng
National University of
Singapore, Singapore



Ian Gibson
National University of
Singapore, Singapore



Marcelo H Ang Jr
National University of
Singapore, Singapore



Chen Jingsheng
National University of
Singapore, Singapore



Qian Xudong
National University of
Singapore, Singapore



Shuaian Wang
National University of
Singapore, Singapore

Advances in Automobile Engineering -Open Access using online manuscript submission, review and tracking systems of Editorial tracking system for quality and quick review processing. Submit your manuscript at <http://www.omicsonline.org/submit/>

OMICS Publishing Group

5716 Corsa Ave., Suite 110, Westlake, Los Angeles, CA 91362-7354, USA, Phone: +1- 650-268-9744, Fax: +1-650-618-1414, Toll free: +1-800-216-6499

Performance Analysis of Hybrid and Full Electrical Vehicles Equipped with Continuously Variable Transmissions

Ahmed Elmarakbi*, Qinglian Ren, Rob Trimble and Mustafa Elkady

Department of Computing, Engineering and Technology, Faculty of Applied Sciences University of Sunderland, Sunderland SR6 0DD, UK

Abstract

The main aim of this paper is to study the potential impacts in hybrid and full electrical vehicles performance by utilising continuously variable transmissions. This is achieved by two stages. First, for Electrical Vehicles (EVs), modelling and analysing the powertrain of a generic electric vehicle is developed using Matlab/Simulink-QSS Toolkit, with and without a transmission system of varying levels of complexity. Predicted results are compared for a typical electrical vehicle in three cases: without a gearbox, with a Continuously Variable Transmission (CVT), and with a conventional stepped gearbox. Second, for Hybrid Electrical Vehicles (HEVs), a twin epicyclic power split transmission model is used. Computer programmes for the analysis of epicyclic transmission based on a matrix method are developed and used. Two vehicle models are built-up; namely: traditional ICE vehicle, and HEV with a twin epicyclic gearbox. Predictions for both stages are made over the New European Driving Cycle (NEDC). The simulations show that the twin epicyclic offers substantial improvements of reduction in energy consumption in HEVs. The results also show that it is possible to improve overall performance and energy consumption levels using a continuously variable ratio gearbox in EVs.

Keywords: Hybrid electrical vehicles (HEVs); Electric vehicle (EV); Continuously variable transmission; Modeling and numerical simulations; Efficiency and energy consumption; Vehicle performance

Introduction

Hybrid Electric Vehicles (HEVs) are considered to be an intermediate step towards purely electric drive (fuel cells or batteries) [1]. Commercial interest in hybrid vehicle technology has grown at a much more dramatic rate than was predicted a decade ago. Around that time, many industry observers were substantially more optimistic about a major leap from current petroleum based technology straight to hydrogen, fuel cells and bio fuel systems. However, it is now widely accepted that hybrid vehicles will have a significant role to play over the next couple of decades as these other technologies continue to be developed.

The development of Power Splitting Transmissions (PST) has been a crucial feature in the technological success of hybrid driveline vehicles. They have played a key role in facilitating the management of the mechanical and electrical power flows, ensuring good drivability, providing improved economy and reducing emissions compared to conventional internal combustion engine vehicles.

HEVs technology has made a massive impact over the past decade on the automotive engineering industry [2,3]. The growth in interest has been fuelled by increasing concerns about the environment and fuel efficiency savings. But also, the market uptake of hybrid vehicles—led mainly by the Toyota Prius—has been much greater than most observers originally predicted; this in turn has led most of the other Original Equipment Manufacturers (OEMs) and Tier One suppliers to develop their own systems, often in collaborative partnerships.

Although many versions of hybrid vehicle have been tried, by far the most common layout is the “series/parallel” hybrid, in which an IC engine and electric motor can either work independently or together. This means that the transmission system must incorporate (a) a power combining device and (b) a regeneration scheme so that the battery can be recharged either by the engine or by the kinetic energy of the vehicle during braking. It is perhaps not widely recognized, but the

transmission design has been a crucial issue in the success of hybrid vehicles. These transmissions are also often referred to as power split devices (PSD)—and the control strategy to manage all the engine, Motor Generator (MG) and transmission elements is also crucial to the goal of achieving improved fuel efficiency from the hybrid vehicle compared with that available from conventional vehicles.

In addition, there has been a massive resurgence of interest in electric vehicles (EVs) over the past decade. Many observers now see them as the long term solution to reducing vehicle emissions and CO₂ usage in comparison to alternative approaches such as hybrid vehicles, fuel cells or biofuels [3,4]. The public perception of electric vehicles has changed dramatically—and recently announced vehicles such as the Tesla roadster and Chevrolet Volt have reinforced the idea that they are now becoming seriously competitive products. Not long ago, electric vehicles were still seen as niche products—and associated more with ‘milk float’ technology rather than a viable passenger transport alternative [5-7].

As the electric vehicles market continues to grow, the vehicle manufacturers will place increasing emphasis on searching for efficiency gains. This process of continual improvement is central to vehicle development and has occurred for example over recent decades with internal combustion engines; the industry has achieved fuel consumption and CO₂ emissions figures that were considered impossible twenty years ago.

***Corresponding author:** Ahmed Elmarakbi, Department of Computing, Engineering and Technology, Faculty of Applied Sciences University of Sunderland, Sunderland SR6 0DD, UK, Tel: +44 191 515-3877; Fax: +44 191 515-2781; E-mail: ahmed.elmarakbi@sunderland.ac.uk

Received February 15, 2013; **Accepted** February 27, 2013; **Published** March 07, 2013

Citation: Elmarakbi A, Ren Q, Trimble R, Elkady M (2013) Performance Analysis of Hybrid and Full Electrical Vehicles Equipped with Continuously Variable Transmissions. Adv Automob Eng 2: 103. doi:10.4172/2167-7670.1000103

Copyright: © 2013 Elmarakbi A, et al. This is an open-access article distributed under the terms of the Creative Commons Attribution License, which permits unrestricted use, distribution, and reproduction in any medium, provided the original author and source are credited.

Despite the high worldwide level of interest in EVs some aspects of the vehicle technology have received little attention. The transmission design is one such area and perhaps it is understandable that the majority of research attention has to date focused on the more obvious topics of batteries, motors and power electronics.

This paper investigates the influence of adding an addition transmission gearbox, in which efficiency gains may be achievable for electric drivelines. It is commonly argued that one of the distinct advantages of an electric motor as a motive unit is its torque characteristic; it can deliver maximum torque from zero speed and throughout the low speed range—typically up to around 2000 rev/min, then, the available maximum torque reduces with speed along the motor’s maximum power curve. This is a much better characteristic than that associated with internal combustion engines, which cannot deliver useful torque at low speeds and because of their relatively narrow torque and power bands must be used with multispeed transmissions in order to deliver tractive power to the vehicle in a suitable form. Typical electric motors have another desirable feature, their maximum intermittent power is considerably higher than their rated continuous power 75 kW compared to 45 kW for the example motor used here. The limiting factor is usually related to controlling the amount of heat build-up. Consequently, good acceleration times can be achieved providing they are only used for relatively short periods, a situation which fortunately is typical of normal driving.

However, the efficiency curves for a typical electric motor are highly dependent on both speed and torque. The motor efficiency tails off rapidly at low speeds and torques where its efficiency might drop to say 50%, whereas in its mid speed and torque range it can be as high as 93%. Consequently, it is of interest to the energy efficient vehicle community to try and quantify any potential gains from utilising a gearbox in order to operate the motor for longer periods in its high efficiency region.

The aim of this paper is to investigate whether there are any potential efficiency or performance benefits for using geared transmissions for EVs. Predicted results are compared for a typical EV without a gearbox, with a CVT and with a conventional stepped gearbox. Predictions are made over NEDC. A generic motor IS modeled in this work in order to understand the sensitivity of the results to the assumptions about motor efficiency maps. Furthermore, the paper focuses on transmissions for hybrid electric vehicles-NexxtDrive system [8] which is marketed as ‘DualDrive’ for automotive and off-highway applications. The transmission provides a Continuously Variable Gearbox (CVT) based on two epicyclic gear sets plus two electric motor/generator units.

Continuously Variable Transmissions

Continuously Variable Transmissions (CVTs) have been around for many years and the cost-benefit issues relating to CVTs are well understood. The potential advantages are improved performance, economy and emissions or more importantly an improved compromise between them. Their disadvantages have been cost, complexity, noise and driving refinement. Only over the past five years or so has the development of CVTs reached a stage at which they are beginning to be genuinely competitive with the alternatives, e.g. conventional, torque converter automatics and automated manual gearboxes, such as the twin clutch VW DSG system.

An important type of CVT is the E-CVT (Electronically-Controlled Continuously Variable Transmission), a good example of which is Toyota Hybrid System (THS). It combines the characteristics of an electric drive and a continuously variable transmission, using motor

generator units in addition to toothed gears [9,10] (Single epicyclic gearbox transmission). In a THS system, one of the motor generators (MG2) is mounted on the driveshaft, and thus couples torque into or out of the driveshaft. The second motor generator (MG1) is connected with the sun gear and used to change the sun gear speed. Because MG2 is connected with the driveshaft, it cannot change speed and torque freely. Hence there are three power input/output branches in the system: the engine, MG1, the output, MG2. Because the speed of the output shaft is decided by the speed of the vehicle, there is some limitation on the control strategy to achieve optimum performance. On the other hand, in a twin epicyclic gearbox transmission system, which is presented in this paper, neither of the motor generator units is mounted on the driveshaft or on the engine input shaft, which gives more freedom and benefits to the system (Figure 1). One motor/generator is connected to the sun gear, and the other motor/generator is connected with a ring gear. So there are four branches of power input/output: the engine, the output shaft, and two motor generator units, MG1 and MG2.

This type of four branch transmission system has been described recently by Moeller [8] who proposed that it offers advantages in many automotive applications. However, its usage in a hybrid electric vehicle driveline will be studied here.

The power flow of the twin epicyclic gearbox is shown in figure 2. As before, MG1 is mainly used as a generator and MG2 is mainly used as a motor; both are connected to the battery, taking or saving electricity from or to the battery. The power of the engine is split into two ways: to the wheel via the ring gear, and to the MG1. The vehicle can be driven on engine alone, the MG2 alone, or combined power, depending on the power required and State Of Charge (SOC) of the battery.

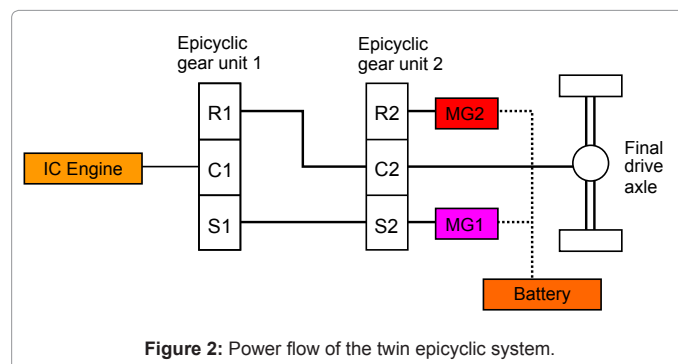
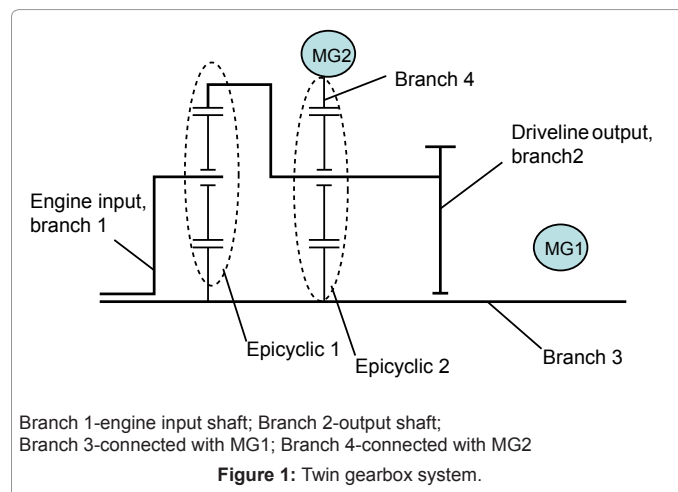

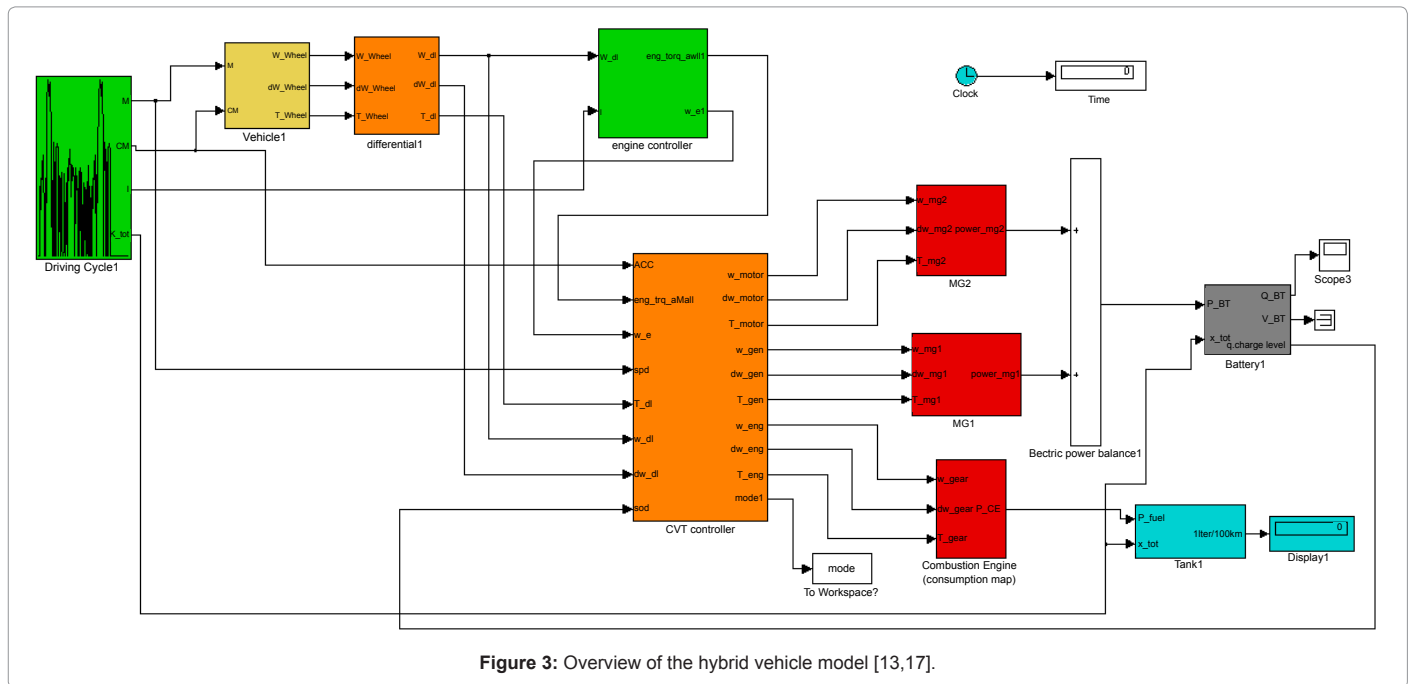

Figure 3: Overview of the hybrid vehicle model [13,17].

A matrix method is used to analyze the planetary transmission system, as introduced by Tian et al. [11]. The key point of this method is to generate matrices to represent all the planetary train elements and other auxiliary components of the transmission. In this approach, the planetary transmissions are broken into finite functioning units, and then matrices are created representing both the configuration relationships between those units and the transmission manipulating characteristics. Once these matrices are generated, the kinematic and dynamic problems of the transmissions can be solved by means of standard matrix operations (See the previous work of the authors for full details of using the matrix method to analyse the CVT) [12].

Hybrid Electrical Vehicle Modelling

The modelling of the hybrid electric vehicle performance is done using the QSS Toolkit [13]. This is a quasi-static simulation package based on a collection of Simulink blocks and the appropriate parameter files that can be run in any Matlab/Simulink environment. The vehicle model is shown in figure 3.

The data for the engine, motor generator and battery are taken from generic data in the QSS package and the other vehicle data is taken as follows: vehicle curb weight=1257 kg; drag coefficient, $C_d=0.29$; frontal area=2.23 m²; Tire radius = 0.292 m; and final drive=3.95:1). It is not intended to represent any specific vehicle but rather to act as a generic vehicle platform to focus attention on the differences obtainable from the two different PST arrangements. The traditional ICE vehicle model itself is straightforward. There are 5 sub-systems: the driving cycle subsystem, vehicle subsystem, the gearbox subsystem, the combustion engine subsystem, and the fuel tank subsystem. The data for the engine and gearbox are taken from generic data in the QSS package as well.

The engine model from QSS Toolbox is used in this research. The function of the engine model is to compute the fuel consumption from a consumption map. Inputs for the model include engine speed, engine acceleration and engine torque. The output of the model is the fuel consumption of the engine at each sampling point. The function of overload and over speed detection is built in the engine model. As

soon as the engine torque or speed is over the limit, the simulation is stopped. The similar detection function is built in the motor/generator models. To finish the simulation with the whole driving cycle, once any overload or over speed is detected, the controller will reselect the related speed and/or torque, to make sure every component, including the engine and the motors, work within these the speed-torque limit.

The data for the fuel consumption map represents a small engine with maximum speed 500 rad/s and maximum torque 118 Nm. There are 3 parameters for the map: a vector ($1 \times n$) containing the rotational speed, a vector ($m \times 1$) containing the torque and an efficiency map ($n \times m$) containing the fuel efficiency point (kg/s) at each combination of speed and torque.

Electric Vehicle Modelling

The modelling of the electric vehicle performance is also done using the QSS Toolkit [13]. The vehicle model itself is straightforward and is shown in figure 4; it is a conventional plug-in type EV with the addition of a gearbox in the power train.

A generic motor is used in this analysis. The generic motor characteristics are intended to represent a typical generic motor of 40 kW. They were taken from Larminie's [7] who presents a Matlab script to generate a set of generic motor properties based on assumptions about the losses within the motor. The schematic diagram of selecting motor operation point is shown in figure 5. The efficiency of each point is calculated, for any given point (x, y), as follows:

$$\eta(x, y) = \frac{Power_{output}}{Power_{input}} = \frac{x \cdot y}{x \cdot y + kc \cdot y^2 + ki \cdot x + kw \cdot x^3 + ConL} \quad (1)$$

Where $kc \cdot y^2$, $ki \cdot x$, and $ConL$ are copper losses, Iron losses, windage losses and constant motor losses respectively. In this study kc , k , kw and $ConL$, 0.2, 0.008, 0.00001 and 400 respectively. Let (x_1, y_1) represent any point along the constant power line on which $power=x \cdot y$, the efficiency could be rewritten as

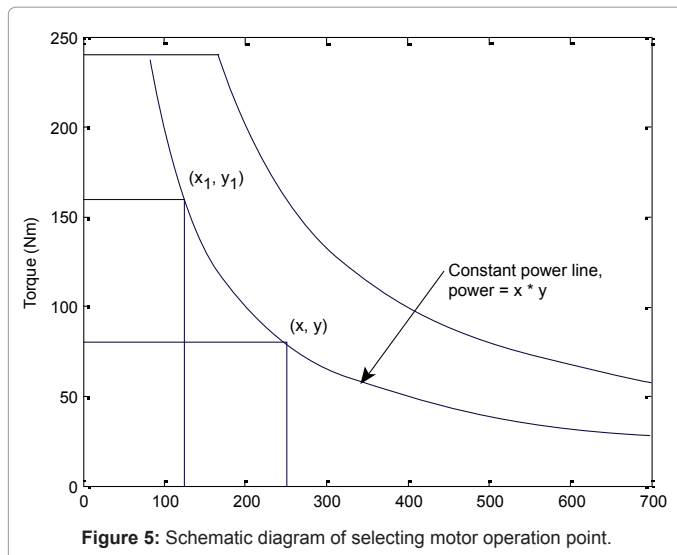
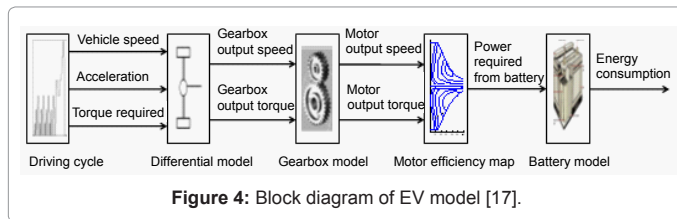

$$\eta(x_1, y_1) = \frac{\text{power} \cdot x_1^2}{kw \cdot x_1^5 + ki \cdot x_1^3 + (\text{power} + \text{ConL})x_1^2 + kc \cdot \text{power}^2} \quad (2)$$

Once the expression of efficiency for any point along the constant power line is given, Matlab can be used to search for the most efficient point.

Simulation Results

The solution procedure is based on stepping through the driving cycle at typically one second steps, calculating the equilibrium condition and then collecting all the data for plotting at the end of the cycle. The modelling assumptions are kept very simple in this initial work, so that no account is included for example of losses in the gear sets or differential. Thus, the focus of attention is on the overall efficiency of the engine and motor generator units and the major issue of whether it is possible to improve overall energy usage by operating the whole system at or near to the best efficiency points.

Hybrid electrical vehicles

Results are generated to investigate the performance of the twin epicyclic transmission system gearbox in a hybrid electrical vehicle. The results are calculated using the New European Driving Cycle (NEDC). The HEV results are also compared against a conventional IC engine plus manual gearbox vehicle. The results focus on fuel consumption comparisons but it is also shown how the twin epicyclic gearboxes use the engine and motor generator units differently.

For HEVs, the difference between the initial and final battery SOC can significantly affect the measurement of fuel economy. To eliminate this effect, the concept of 'Overall Fuel Consumption (OFC)' is introduced. The total additional energy stored or drawn from the battery (kWh) is calculated and then converted into how much fuel

(liter) would be used for the engine to produce this amount of energy [14-17].

i) Engine fuel consumption (EFC, liter/100 km): actual fuel burned by the engine divided by the driving distance;

ii) Overall fuel consumption (OFC, liter/100 km): the fuel consumption after taking the Battery Energy Changed (BEC) into consideration.

$$OFC = EFC + \frac{100 \times BEC \times \eta_{eng}}{\rho} / D \quad (3)$$

Where ρ is the fuel density (g/ml), η_{eng} is the engine efficiency (g/kWh) and D is the driving distance (m). The values for ρ and η are taken as 0.76 g/ml and 240 g/kWh, respectively. In the simulation, BEC is positive if energy is drawn from the battery and negative if the energy is stored into the battery. So at the end of each driving cycle, if final SOC is smaller than the initial SOC, namely the energy is drawn from the battery, overall fuel consumption is greater than the engine fuel consumption, and vice versa.

It is very important to take account of the battery SOC in the calculations, because if it is different at the end of the driving cycle from its value at the start then some net energy has effectively been lost or gained in the vehicle calculations. In several examples of results in the literature, it is not clear whether this effect has been accounted for. Also, some researches actually use the control system to ensure that the battery start and finish conditions are exactly the same. However, this can cause difficulties because the control system is not necessarily representative of what it would be doing during normal practical driving.

The first set of results is used to compare the HEVs equipped with a twin epicyclic transmission with a baseline, conventional vehicle equipped with a five speed gearbox (3.84, 2.11, 1.36, 0.86 and 0.63 with the same final drive ratio). The control strategies is based on a rule-based approach to compromise between overall energy efficiency and maintaining the battery State Of Charge (SOC) under control. Using the NEDC driving cycle, the overall fuel consumption results are presented in table 1.

As expected, the hybrid vehicles show economy advantages over the conventional, manual gearbox vehicle. However, the improvements are not as great as published in some other studies, but this is understandable because the systems used here and in particular their controllers have not yet been optimized.

The associated engine utilization maps for the baseline gearbox and the twin epicyclic gearbox vehicle are shown in figures 6 and 7, respectively. Each point on the map of engine torque vs. speed is the solution at a single point during the NEDC cycle; the cycle defines input from $t=0$ s to $t=1220$ s. However, the NEDC cycle contains a percentage of constant speed running conditions, so that several points will sit on top of each other. First, these results highlight in figure 6 the shortcoming associated with conventional IC engine cars—namely that they inevitably spend considerable time at part load conditions

Driving Cycle	Fuel consumption over driving cycle, l/100 km		
	Traditional Vehicle	HV with twin epicyclic system	
		Engine FC	Overall FC
NEDC	3.8	3.9	2.5

Table 1: Comparisons of fuel consumption for the hybrid vehicle fitted with twin epicyclic systems compared with a conventional, manual gearbox vehicle over NEDC cycle.

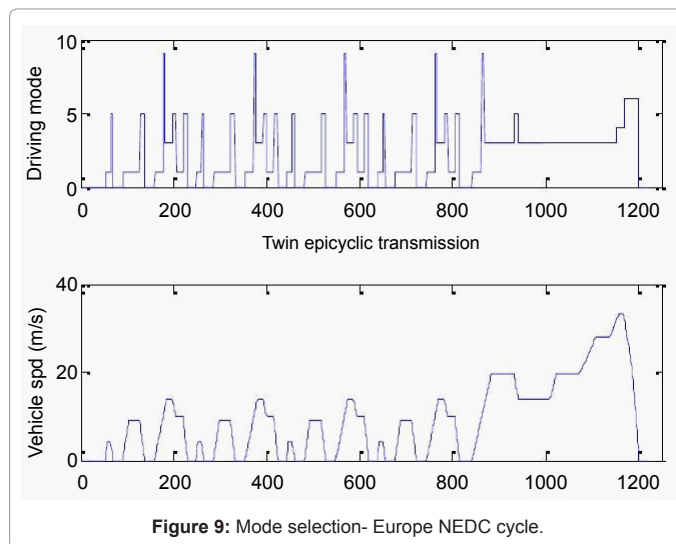
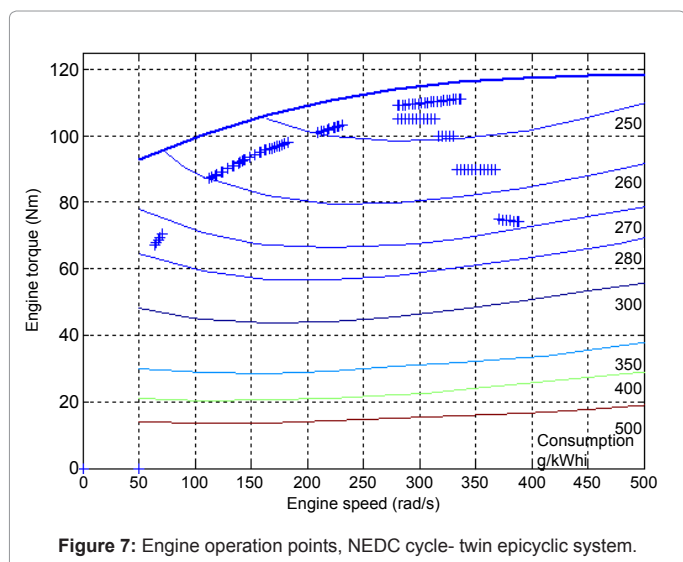
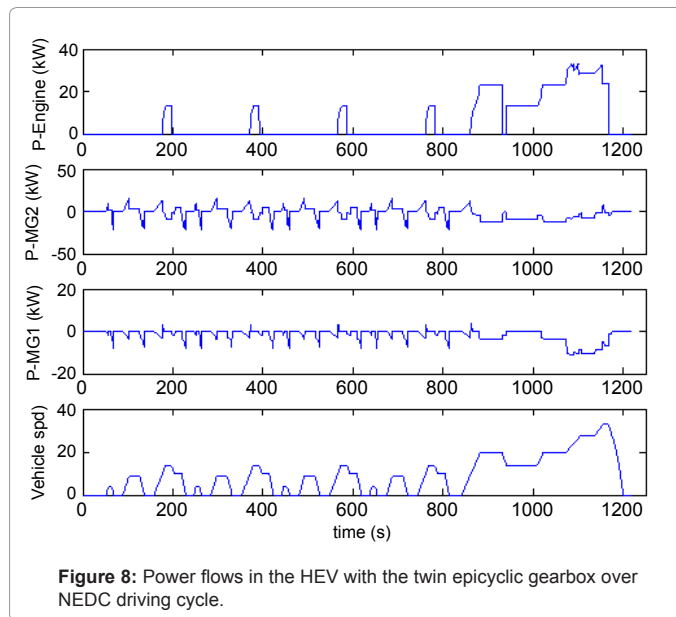
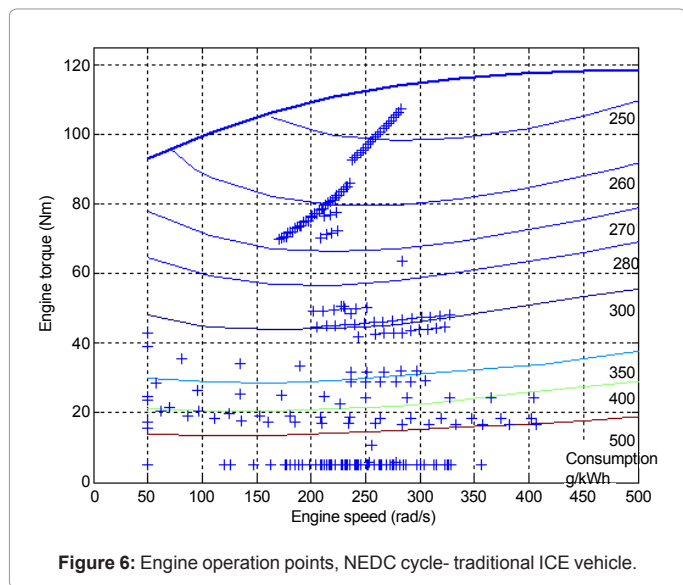

well away from the areas of maximum efficiency. It is observed from Figure 7 that the twin epicyclic gearbox actually manages some further improvement and also reduces the use of the higher engine speeds.

Further insight into the detailed behavior of the twin epicyclic gearbox can be seen in the time history plots in figure 8 for the NEDC cycle. The power utilization of the IC engine and two motor generator units, MG1 and MG2 are plotted along with the vehicle speed profile specified in each of these driving cycles.

For HEVs with twin epicyclic transmission, the selection of driving mode during NECD cycle is shown in figure 9. The main difference is that for twin epicyclic transmission, one more mode: high efficiency mode is selected.

The HEV with the twin epicyclic transmission, the operation points of MG1 and MG2 over NEDC cycle are shown in figures 10 and 11. For both MG1 and MG2, the control strategies were designed that the motor/generators work within the maximum torque curve. If one of the calculation points suggests that one of the electric machines is over speed or overload, the controller will change the speed and/or torque

of the engine to make sure every element is working in the correct operation range.

Electrical vehicles

The vehicle parameters for the EV with the generic motor are as follows: total vehicle mass=950 kg; wheel diameter=0.5 m; aerodynamic drag coefficient=0.22; frontal area=2 m², rolling resistance coefficient=0.008; motor maximum torque=240 nm; motor maximum speed 800 rad/s; motor power=40 kW; and final drive ratio=3.5. They are intended to be representative of a typical generic vehicle rather than any specific design. The motor rated power is 40 kW, and the total vehicle mass is set to be 950 kg.

Electrical vehicles with continuously variable gearing

The next results assume that the gearbox is infinitely variable so that any ratio can be selected; in fact upper and lower limits are applied so that the ratio can be any value between 4 and 0.6. The calculation procedure is effectively a simplified optimization strategy. At any point

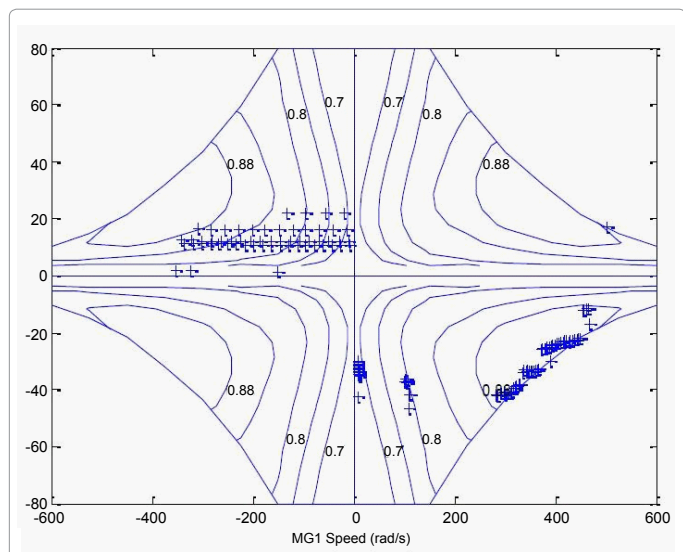

Figure 10: Operation of MG1, twin epicyclic system.

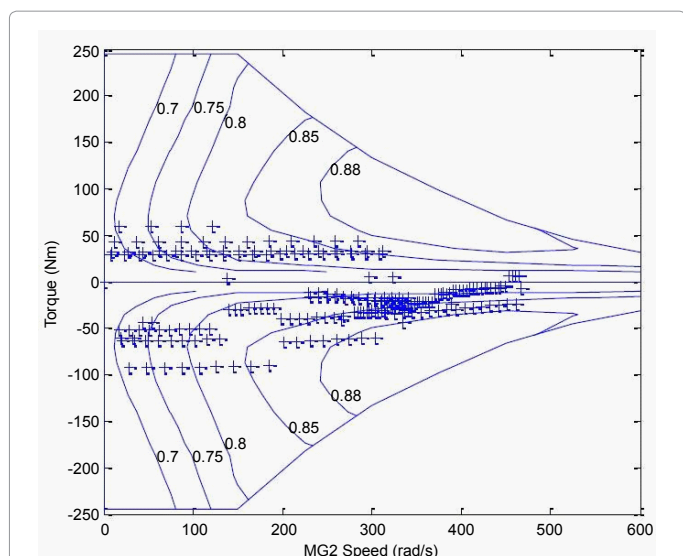

Figure 11: Operation of MG2, twin epicyclic system.

in the drive cycle, the torque and speed demanded of the motor are first calculated; then, for this power requirement a search routine is used with the motor map to find the point of maximum efficiency and the appropriate gear ratio selected so that the motor can operate at this point and still deliver the necessary torque and speed to the driving wheels.

It is further assumed that the gearbox response would be fast enough to follow these changing requirements. Thus, the results shown in figure 12 effectively describe the optimization of the motor usage over the selected NEDC drive cycle. It is clear from figure 12 that the results follow the nominal line of maximum efficiency of the motor. The gear ratios selected by the algorithm to achieve this are shown in figure 13.

Electrical vehicles with a multispeed gearbox

The results shown in figure 14 refer to the case in which it is assumed

that a four speed gearbox is fitted in the transmission. The ratios are selected in a rather subjective fashion after inspection of figure 13, and are 2.5, 1.5, 1 and 0.8; in practice, the gear ratio selection would be done automatically rather than manually as with a conventional IC engine car. Here, a simplistic gear selection strategy is used:

i) For constant speed running the highest gear (lowest numerical ratio) is selected

ii) When accelerating, the ratio is based simply on speed – such that the above ratios are selected for the speed ranges 0-100, 100-200, 200-300 and 300-800 rad/s.

It is not suggested that this is in any way optimal, but this approach is chosen to understand the sensitivity of the energy usage predictions to practical design issues.

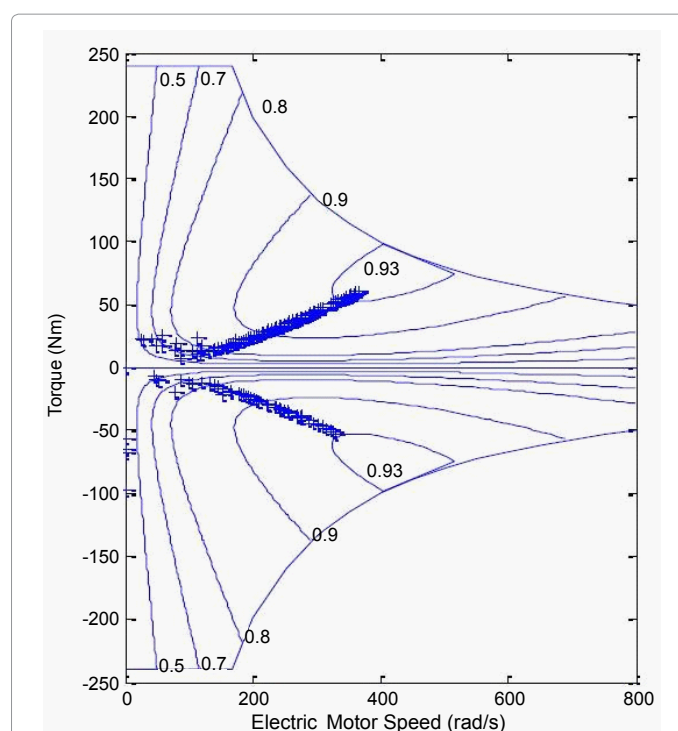

Figure 12: Motor operation points with continuously variable gear.

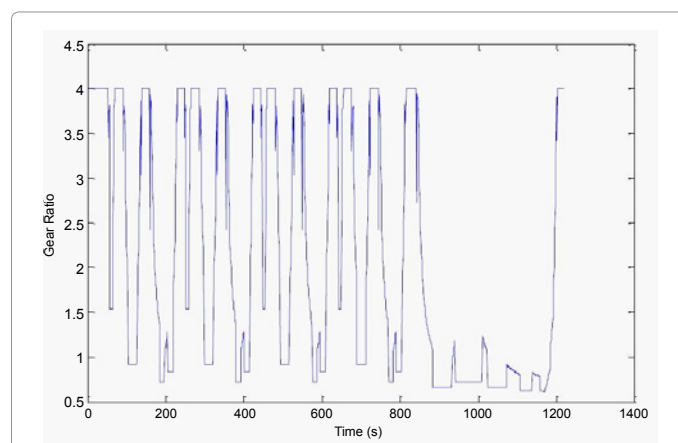

Figure 13: Gear ratios selected by optimization strategy.

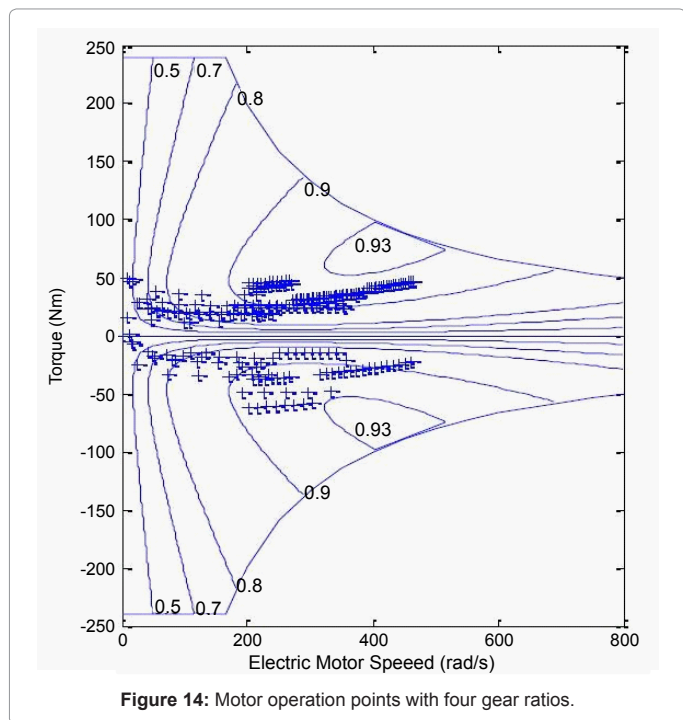

Figure 14: Motor operation points with four gear ratios.

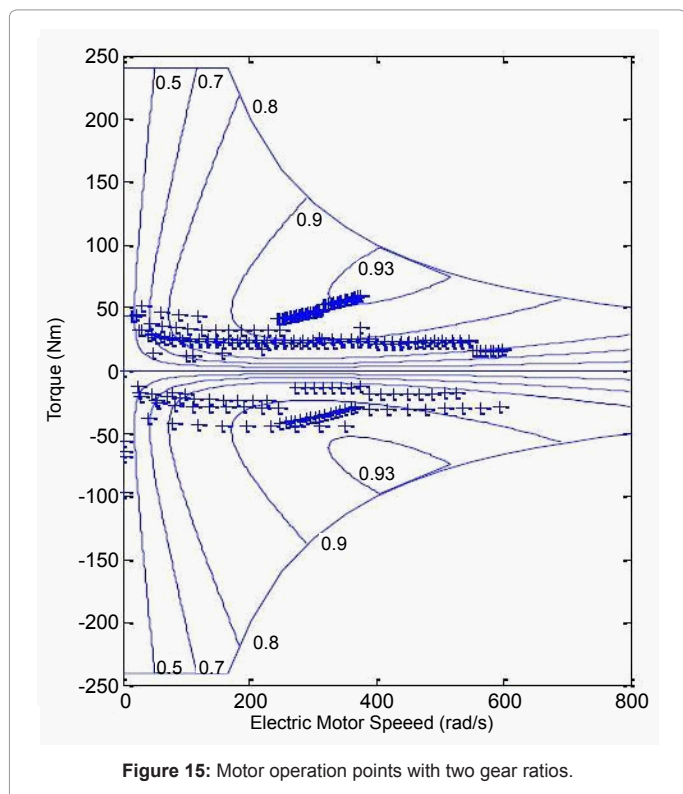

Figure 15: Motor operation points with two gear ratios.

The results are then repeated for two other gearboxes:

- i) 3 speed with ratios of 2, 1 and 0.8
- ii) 2 speed with ratios of 2 and 0.8 for the speed ranges 0-300 and 300-800 rad/s

The motor operation points for the 2 gear system are shown in

	Energy consumption per 100km (kWh/100km)	Improvement %
No gear	8.33	-
CVT	7.89	5.28
4 speed	7.96	4.45
3 speed	8.01	3.76
2 speed	8.10	2.71

Table 2: Efficiency improvements for different gearboxes over the NEDC cycle.

figure 15. The results are summarized in table 2 showing the relative energy consumptions for the different geared systems over the NEDC cycle. The improvements resulting from fitting an additional gearbox are actually rather modest over the NEDC cycle. The percentage improvements would, in practice, be immediately cancelled out by the additional efficiency losses in the gearbox itself, which have initially been ignored in this work. For the vehicle with a generic motor, using the NEDC cycle the efficiency improvement assuming a continuously variable gearbox is fitted is 5.28% for the typical generic vehicle used as depicted in table 2. Improvements of around 12.4% is also achieved over the USA FTP-75 cycle, however, the NEDC was the focus of this paper.

One of the potential advantages of a geared transmission relates to possible improvements in drivability. For example, the 0 to 100 km/h acceleration time of the fixed gear vehicle is 18.3 s, whereas with just 2 gears, this time is reduced to 12.4 s. The top speed of 183 km/h of course remains unchanged.

This raises the possibility that one of the advantages of a simple geared system would be to downsize the motor, but still retain the same drivability characteristics. Whether this is a practical proposition will depend largely on the specific vehicle application, and the detailed properties of the motor selected relative to the critical vehicle properties of mass, rolling resistance and aerodynamic drag. For example, although the NEDC is widely used as a standard driving cycle, the peak power demanded from the motor is only 21.9 kW. In practice, the peak power of the motor would have to be around double this value in order to provide a sufficiently high level of acceleration to meet customer demands. So the effect of the continuously variable gearbox over these conditions is to offer a greater improvement.

The consumer acceptance of alternative power trains depends on much more than just the headline economy figure and society's reaction to the feeling of contributing to the green economy. Vehicles still need to be pleasurable, convenient and satisfying to drive. Many of these aspects of driving dynamics are captured under the title of 'drivability'. Attempts have been made to quantify aspects of drivability and to a limited extent this has proved possible by defining new metrics. However, the interesting but elusive feature of drivability is that much of the assessment is based on qualitative judgements and the subjective impressions of the driver.

One of the challenges facing the industry is temptation to optimize their design around achieving a top result in the driving cycle test—thus resulting in leading headline figures for fuel economy and carbon dioxide usage. Overall, this is clearly not a desirable situation—when the nature of the test procedure actually drives the engineering development of the vehicle. It also raises another major area for research into energy efficient vehicles—referred to as 'drivability'. This term is used to cover an extensive range of vehicle properties which result in the drivers' satisfaction levels with the car. The future work could focus the drivability of electric vehicles with different transmissions.

Some of the aspects used to assess drivability include; idle conditions, launch feel, 'throttle' response and feel, cruise stability, tip-in, tip-out, shunt oscillations, brake feel and brake blending with regeneration etc. There is clearly a future research opportunity to investigate whether there are robust relationships between measurable vehicle properties and the subjective assessments of drivers.

Conclusions

The promising outcomes from this work are listed below; these must be interpreted in the context of the modeling approach used. The analysis is kept at a simple level in order to gain an initial understanding of whether the introduction of a geared transmission into an electric drive train offers any potential.

- For the vehicle with a generic motor, using the NEDC cycle the efficiency improvement assuming a continuously variable gearbox is fitted is only 5.3% for the typical generic vehicle used.

- Using a simple two speed gearbox offers a worthwhile performance improvement of over the NEDC cycle.

- Other potential benefits of a transmission system may be in overall drivability and the potential to downsize the motor somewhat whilst retaining acceleration capability for the limited times that maximum acceleration is required.

- Overall, this simplified modeling suggests that the idea of using a geared transmission in an electric vehicle is worthy of further research using a more sophisticated driveline model and attempting to quantify both efficiency gains and drivability improvements.

- For the twin epicyclic gearbox, it is shown over a limited range of operating conditions that it is possible to direct less power via the electrical route, thus offering potential efficiency gains.

- The twin epicyclic gearbox arrangement offers a significant performance benefit with fuel economy improvements.

- The performance benefits arise from the greater flexibility of control over the torques, speeds and power flows through the two motor generator units available with the dual epicyclic scheme.

Acknowledgement

The authors acknowledge with sadness, the contribution of Prof. Dave Crolla who has passed away during the period of this research.

References

1. Cole AC, Mann D (2009) Unravelling and resolving hybrid electric vehicle design conflicts.
2. John MM (2006) Hybrid electric vehicle propulsion system architectures of the e-CVT type. IEEE T Power Electr 21: 756-767.
3. Ehsani M, Gao Y, Emadi A (2009) Modern Electric, Hybrid Electric, and Fuel Cell Vehicles: Fundamentals, Theory, and Design, Second Edition. CRC Press, USA.
4. Mehrdad ES, Yimin G, John MM (2007) Hybrid Electric Vehicles: Architecture and Motor Drives. P IEEE 95: 719-728.
5. Chan CC, Chau KT (2001) Modern Electric Vehicle Technology. Oxford University Press, UK.

6. Husain I (2003) Electric and Hybrid Vehicles: Design Fundamentals. CRC Press, USA.
7. Larminie J, Lowry J (2003) Electric Vehicle Technology Explained. John Wiley & Sons, USA.
8. Moeller F (2006) Power combining single regime transmissions for automotive vehicles. IMechE Integrated Powertrain and Driveline Systems Conference (IPDS 2006), London, UK.
9. <http://www.edmunds.com/toyota/prius/2006/>
10. Miller JM, Miller JNJ (2005) Comparative Assessment of Hybrid Vehicle Power Split Transmissions. VI Winter Workshop Series.
11. Tian L, Li-qiao L (1997) Matrix System for the Analysis of Planetary Transmissions. J Mech Des 119: 333-337.
12. Dave C, Qinglian R (2007) Analysis of a continuously variable transmission based on a twin epicyclic power split device. SAE paper.
13. <http://www.idsc.ethz.ch/>
14. Hofman T, Steinbuch M, van Druuten RM, Serrarens AFA (2008) Rule-Based Equivalent Fuel Consumption Minimization Strategies for Hybrid Vehicles. Proceedings of the 17th World Congress. The International Federation of Automatic Control Seoul, Korea.
15. Suzuki M, Yamaguchi S, Araki T, Raksincharoensak P, Yoshizawa M M, et al. (2008) Fuel Economy Improvement Strategy for Light Duty Hybrid Truck Based on Fuel Consumption Computational Model Using Neural Network. Proceedings of the 17th World Congress. The International Federation of Automatic Control Seoul, Korea.
16. Sharer P, Leydier R, Rousseau A (2007) Impact of Drive Cycle Aggressiveness and Speed on HEVs Fuel Consumption Sensitivity. SAE International.
17. Ren Q (2010) Numerical analysis and modelling of transmission systems for hybrid electric vehicles and electric vehicles. Department of Computing, Engineering and Technology, University of Sunderland, UK.

Citation: Elmarakbi A, Ren Q, Trimble R, Elkady M (2013) Performance Analysis of Hybrid and Full Electrical Vehicles Equipped with Continuously Variable Transmissions. Adv Automob Eng 2: 103. doi:10.4172/2167-7670.1000103

Submit your next manuscript and get advantages of OMICS Group submissions

Unique features:

- User friendly/feasible website-translation of your paper to 50 world's leading languages
- Audio Version of published paper
- Digital articles to share and explore

Special features:

- 250 Open Access Journals
- 20,000 editorial team
- 21 days rapid review process
- Quality and quick editorial, review and publication processing
- Indexing at PubMed (partial), Scopus, EBSCO, Index Copernicus and Google Scholar etc
- Sharing Option: Social Networking Enabled
- Authors, Reviewers and Editors rewarded with online Scientific Credits
- Better discount for your subsequent articles

Submit your manuscript at: <http://www.omicsgroup.info/editorialtracking/pancreatic-disorders>